

# 31.5" 4K Medical Display

## FM-F3101D, FM-F3101DG



- *OLED technology. High contrast ratio. Perfect blacks.*
- *High brightness, large color gamut display.*
- *Multi window (2, 3, 4) layouts built in.*
- *Image rotate (90, 180, 270) and mirror (horizontal, vertical).*
- *Front filter bonding increases picture quality and durability.*

### OLED Technology for Surgery

Experience ultra clear picture quality with FSN's FM-F3101D series medical grade monitors. Using OLED technology, these models offer true blacks, better contrast, power efficiency, and lighter weight. The user interface allows for complete control of image characteristics, including multi-window layouts.



These monitors are compatible with highly specialized visualization equipment used in operating rooms and surgical suites. FSN's attention to detail allows for safe and efficient interaction by medical personnel. FM-F3101D series delivers everything that professionals need in state-of-the-art surgical monitors.



**HDR 10** High Dynamic Range (HDR)/HLG ready, offering brighter highlights, darker blacks, and generally richer, more vivid color.

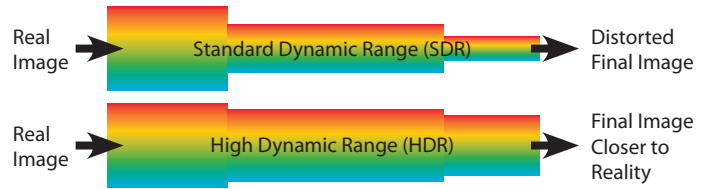

Multiple source support.

### OLED offers better:

- Picture Quality
- Response Time
- Weight
- Energy Efficient
- Deep Black Levels - High Contrast Ratio

### FM-F3101D

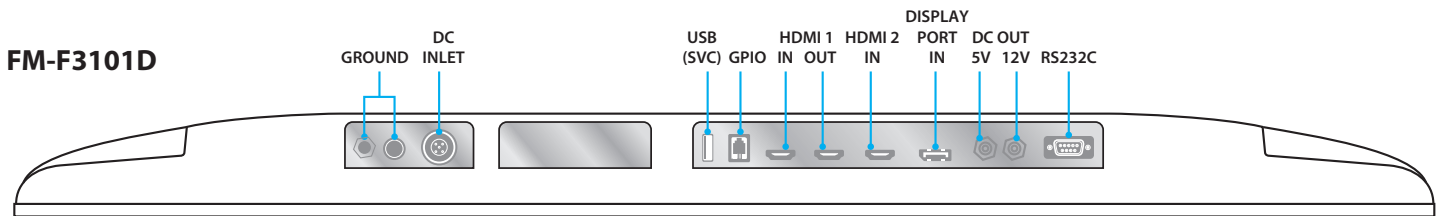

### FM-F3101DG

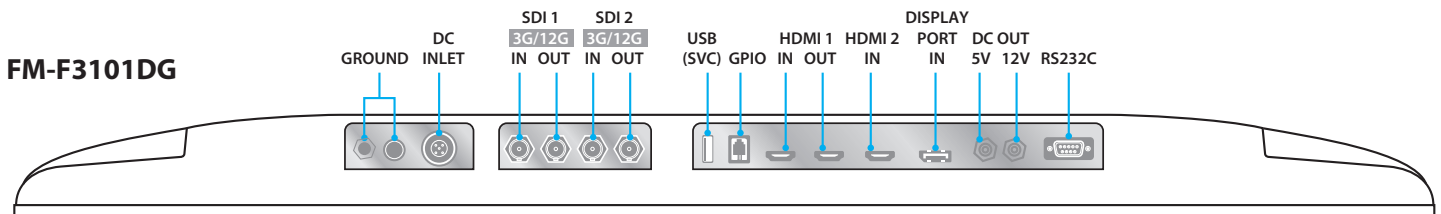

# 31.5" 4K Medical Display

## FM-F3101D, FM-F3101DG



## Specifications

### General Features

Item	Description
Panel	31.5 inch OLED
Resolution	3840 x 2160 pixels
Active Area	697.92 (H)mm x 392.6 (V)mm
Pixel Pitch (mm)	0.18175 x 0.18175
Response Time (typical)	< 0.2 ms (rise + fall time)
Pixels Arrangement	RGB vertical stripes
Number of Colors	1.07 Billion
Brightness (typical)	540 cd/m <sup>2</sup> peak
Color Gamut	BT.709 and BT.2020 compatible
Contrast Ratio (typical)	1,000,000 : 1
Surface Treatment	Anti-reflection
Viewing Angle (CR>10)	R/L 178°, U/D 178°
Input Signal	FM-F3101D
	2 x HDMI 2.0
	1 x DP 1.4 (SST)
	FM-F3101DG
2 x HDMI 2.0	
1 x DP 1.4 (SST)	
2 x SDI (3G, 12G)	

Item	Description
Output Signal	FM-F3101D
	1 x HDMI 2.0
Output Signal	FM-F3101DG
	1 x HDMI 2.0 2 x SDI (3G, 12G)
Power Input	AC/DC Adaptor (AC 100~240V, DC 24V/6.6A)
Power Output	DC Output (1 x 12V/2A, 1 x 5V/2A)
Power	FM-F3101D
Consumption	FM-F3101DG
Accessories Included	User manual, AC-DC adaptor, AC power cord, DP cable, HDMI cable, SDI cable (FM-F3101DG), M4 screws.
Latency (typical)	1 ms
Unit Dimension	757(W) x 464(H) x 54.7(D) mm 29.8(W) x 18.27(H) x 2.15(D) inch
Package Dimension	860(W) x 780(H) x 200(D) mm 33.86(W) x 30.71(H) x 7.87(D) inch
IP Rating	IP33 - overall
Weight	FM-F3101D
	9.06 kg, 19.97 lbs. (monitor with cover) 13.91 kg, 30.67 lbs. (shipping package)
Weight	FM-F3101DG
	9.23 kg, 20.35 lbs. (monitor with cover) 14.13 kg, 31.15 lbs. (shipping package)
Certifications	ANSI/AAMI ES60601-1 (UL60601-1), CAN/CSA C22.2 No. 60601-1, FCC Class B, EN60601-1, EN60601-1-2, CE, MDR(EU) 2017/745 Class I Medical Device

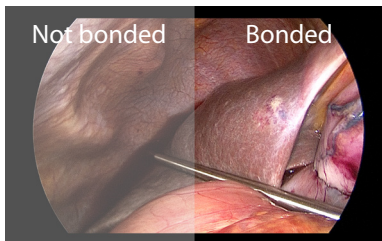
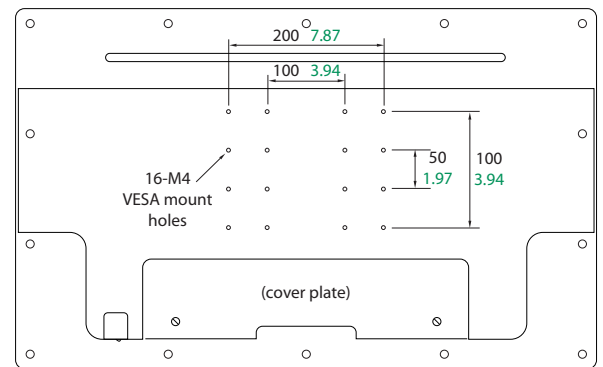
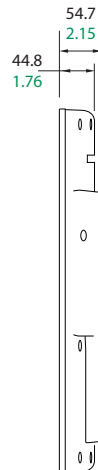
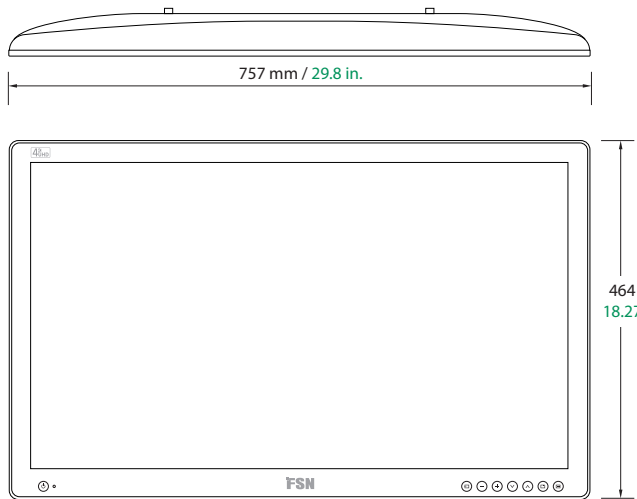

FSN's optical bonding process (right) improves contrast ratio and brightness, and increases humidity resistance and breakage resistance.

FSN Medical Technologies products meet EU RoHS Directive 2011/65/EU+2015/863/EU and Registration, Evaluation, Authorisation and Restriction of Chemicals (REACH) obligations. FSN manages the information flow as required by regulations.

Specifications are subject to change with or without notice. Doc. # FSN2064 Rev. 2/23

[www.fsnmed.com](http://www.fsnmed.com)

Foreseeson Custom Displays, Inc.  
2210 E. Winston Road  
Anaheim, CA 92806 USA  
Tel: 714-300-0540  
Fax: 714-300-0546

Latin America  
Aventura, FL 33180 USA  
Tel: 714-507-3855

Foreseeson Korea  
B-408, U-Space2  
670 Daewangpangyo-ro,  
Bundang-gu, Seongnam-si  
Gyeonggi-do, Republic of Korea  
Tel: +82-31-8017-0780

Foreseeson GmbH  
Industriestrasse 38a  
63150 Heusenstamm, Germany  
Tel: +49 6104 64398 0  
Fax: +49 6104 64398 11

Foreseeson UK Ltd.  
1 Wolsey Road  
East Molesay  
Surrey  
KT8 9EL  
United Kingdom  
Tel: +44 (0) 208 546 1047

Foreseeson (Shanghai)  
Medical Equipment Co., Ltd.  
Room 8E, No. 89 Building  
1122 North Qinzhou Road  
Xuhui, Shanghai 200233, China  
Tel: 86-21-6113-4188